

# American National Standard

*Recommended  
Erection Instructions for Steel Frames*

---



Standards As Tough As Steel.™

SPONSOR

Steel Door Institute

Approved January 17, 2012



**This page left intentionally blank.**

**ANSI/SDI®**  
**A250.11-2012**  
Revision of ANSI/SDI A250.11-2001

American National Standard  
**Recommended**  
**Erection Instructions**  
for Steel Frames

Secretariat  
**Steel Door Institute**

Approved June 10, 2011  
**American National Standards Institute, Inc.**

# American National Standard

Approval of an American National Standard requires verification by ANSI that the requirements for due process, consensus, and other criteria for approval have been met by the standards developer.

Consensus is established when, in the judgement of the ANSI Board of Standards Review, substantial agreement has been reached by directly and materially affected interests. Substantial agreement means much more than a simple majority, but not necessarily unanimity. Consensus requires that all views and objections be considered, and that a concerted effort be made toward their resolution.

The use of American National Standards is completely voluntary; their existence does not in any respect preclude anyone, whether they have approved the standards or not, from manufacturing, marketing, purchasing, or using products, processes, or procedures not conforming to the standards.

The American National Standards Institute does not develop standards and will in no circumstances give any interpretation of any American National Standard. Moreover, no person shall have the right or authority to issue an interpretation of an American National Standard in the name of the American National Standards Institute. Requests for interpretations should be addressed to the secretariat or sponsor whose name appears on the title page of this standard.

**CAUTION NOTICE:** This American National Standard may be revised or withdrawn at any time. The procedures of the American National Standards Institute require that action be taken periodically to reaffirm, revise, or withdraw this standard. Purchasers of American National Standards may receive current information on all standards by calling or writing the American National Standards Institute.

Published by

**Steel Door Institute**  
**30200 Detroit Road, Cleveland, Ohio 44145-1967**

Copyright © 2012 by Steel Door Institute  
All rights reserved.

No part of this publication may be reproduced in any form, in an electronic retrieval system or otherwise, without prior written permission of the publisher.

Printed in the United States of America

ANSI/SDI A250.11-2012

## Contents

	Page
1 Scope.....	1
2 Storage and Preliminary Assembly.....	1
3 Plumbing and bracing frames.....	2
4 Accessories.....	3
5 New masonry construction.....	4
6 Existing masonry construction.....	4
7 Steel stud wall construction, studs erected with frame.....	5
8 Double egress frames in steel stud wall construction.....	6
9 Wood stud construction (studs erected with frame).....	7
10 Wood/steel stud construction (studs erected before frame).....	9
11 Slip-on drywall.....	10
12 Butted or Existing Steel or Wood Stud Wall Construction.....	11

## Figures

1 Examples of the accuracy to be maintained while setting frames..	2
2 Spreader.....	3
3 Plumbing the frame.....	3
4 Bracing the frame.....	3
5 Rubber silencers.....	4
6 Extended base anchor.....	4
7 New masonry construction.....	4
8 Masonry anchors.....	4
9 Existing masonry construction.....	5
10 Rough Opening.....	5
11 Existing masonry or concrete wall anchors.....	5
12 Steel stud wall construction.....	5
13 Channel type steel stud.....	6
14 Erect frame.....	6
15 Anchor jambs.....	7
16 Anchor header.....	7
17 Erect frame.....	7
18 Wood stud wall construction.....	8
19 Weld in strap anchors wood/steel studs.....	8

	Page
<b>20</b> Snap or weld in anchors wood/steel studs .....	8
<b>21</b> Z Type weld in anchors steel studs.....	8
<b>22</b> Rough opening shown in wood stud.....	9
<b>23</b> Wood stud wall construction.....	9
<b>24</b> Weld in strap anchors wood/steel studs .....	9
<b>25</b> Snap or weld in anchors wood/steel studs .....	10
<b>26</b> Z Type weld in anchors steel studs.....	10
<b>27</b> Rough opening .....	10
<b>28</b> Align corner gussets.....	11
<b>29</b> Level and square frame .....	11
<b>30</b> Anchor adjusting screw .....	11
<b>31</b> Fasten base anchors to wall stud .....	11
<b>32</b> Hole plug mount.....	12
<b>33</b> Countersink mount .....	13

**Annexes**

<b>A</b> Manufacturing Tolerances for Standard Steel Doors and Frames .....	14
<b>B</b> Installation Exceptions .....	20

**Foreword** (This Foreword is not part of American National Standard A250.11-2012)

The material contained in this document has been developed under the auspices of the Technical Committee of the Steel Door Institute.

Suggestions for improvement gained in the use of this standard will be welcome. They should be sent to the Steel Door Institute, 30200 Detroit Road, Cleveland, OH 44145-1967.

The organizations that have approved this standard are part of the ANSI A250 Accredited Standards Committee, formed February 8, 1991, and are as follows:

American Institute of Architects  
Architectural Testing  
Builders Hardware Manufacturers Association  
Canadian Steel Door Manufacturers Association  
Cedar Valley Associates  
Door and Hardware Institute  
FM Approvals  
Hollow Metal Manufacturers Association/Division of NAAMM  
Intertek Testing Services  
Door Control Services  
Wind Science & Engineering Research Center  
Steel Door Institute  
Therma-Tru  
Underwriters Laboratories Inc.  
Vetrotech / Saint Gobain

The Technical Committee of the Steel Door Institute, which developed this standard, had the following personnel at the time of approval:

Claus D. Heide, *Chairman*  
Mike Torres, *1<sup>st</sup> Vice Chairman*  
Tom R. Janicak, *2<sup>nd</sup> Vice Chairman*  
J. Jeffery Wherry, *Manager*

<i>Organization Represented</i>	<i>Name of Representative</i>
Ceco Door Products.....	Tom R. Janicak
Curries Company .....	Dave Dedic
Deansteel Manufacturing Co.....	Claus D. Heide
Door Components Inc. ....	Tom Popow
Mesker Door Company .....	Mike Torres
Metal Products Inc. ....	Tom Stone
Pioneer Industries.....	Kamal Sheikh
Republic .....	Steven Huguely
Security Metal Products .....	Terry Simpson
Steelcraft .....	Karen Bishop
Steel Door Institute.....	J. Jeffery Wherry

**This page left intentionally blank.**



## American National Standard

# Recommended Erection Instructions for Steel Frames

## 1 Scope

**1.1** Recommended methods for the installation of steel frames for swinging doors in a variety of wall conditions, commonly used in commercial buildings, are covered within this standard. The installation of transom/sidelight (or panel) type frames and single or multiple borrowed lights are not covered in this standard.

**1.1.1** It is not the intention of this document to obstruct the development of alternative installation methods, nor is it intended to restrict frame installation solely to the wall types noted herein.

**1.1.2** Although this document is commonly referenced for severe windstorm installations, critical performance requirements (such as type, quantity, and location of anchors) shall be as indicated in the manufacturer's published Approvals or Listings.

## 1.2 Reference documents

SDI 127E-2006, *Prime Painted Materials Alert*

SDI 127F-2010, *Butted Frames Rough Opening Sizes*

SDI 127J-2010, *Back-Coating of Frames*

SDI 117-2009 *Manufacturing Tolerances for Standard Steel Doors and Frames*

NFPA 80-2010, *Standard for Fire Doors and Other Opening Protectives* (National Fire Protection Association, 1 Batterymarch Park, Quincy, MA 02269; www.nfpa.org)

UL10C-2009 *Standard for Safety Positive Pressure Fire Tests of Door Assemblies*

ANSI/SDI A250.8-2003(R2008) *Recommended Specifications for Standard Doors and Frames*

HMMA 840-07, *Installation and Storage of Hollow Metal Doors and Frames*

HMMA 841-07, *Tolerances and Clearances for Commercial Hollow Metal Doors and Frames*

**1.2.1** Further information on wall construction, anchoring, details, manufacturing tolerances or installation may be found in the following:

SDI 110-2009, *Standard Steel Doors and Frames for Modular Masonry Construction*

SDI 111-2009, *Recommended Standard Details for Steel Doors, Frames, Accessories and Related Components*

SDI 122-2007, *Installation and Troubleshooting Guide for Standard Steel Doors and Frames*

SDI 127D-2006, *Electric Strikes in Stud Walls*

## 1.3 Metrication

**1.3.1** Standard dimensions used in this document are in inch-pound units. Metric values, where applicable, are included in parenthesis for reference only. These are "soft conversion" approximates.

## 2 Storage and Preliminary Assembly

(see SDI 127E, and ANSI/SDI A250.8)

**2.1** All frames, including knocked-down, shall be stored under cover.

**2.1.1** Knocked-down frames shall be placed flat on at least 4" (102 mm) wood sills to prevent the frames from resting on the ground.

**2.1.2** Assembled frames shall be stored vertically. The units shall be placed on at least 4" (102 mm) high wood sills or in a manner that will prevent rust or damage.

**2.1.3** The use of non-vented plastic or canvas shelters that can create a humidity chamber shall be avoided.

**2.1.4** Refer to project specifications for required cleanup and touchup work.

**2.2 Back-Coating** (see SDI 127J for further information)

**2.2.1** When temperature conditions necessitate the use of anti-freezing agents in plaster or mortar, the inside of the frame shall be coated at the jobsite with a corrosion resistant coating by the contractor responsible for installation.

**2.3 Grouting of frames** (see ANSI/SDI A250.8 for further information)

**2.3.1** Where grouting is required in masonry installations, frames shall be braced or fastened in such a way that will prevent the pressure of the grout from deforming the frame members.

**2.3.2** Grout shall be mixed to provide a 4" (102 mm) maximum slump consistency, and be hand troweled into place. Grout mixed to a thinner "pumpable" consistency shall not be used.

**2.3.3** Standard mortar protection in frames is not intended for thin consistency grout. Steel frames, including fire rated frames, do not require grouting. Grouting is not recommended for frames installed in drywall.

**2.4 Assembly of frame/anchor provisions**

**2.4.1** Follow manufacturers' recommended procedure for assembly of frame and quantity and spacing of anchors. If not indicated, install anchors at hinge levels and directly opposite at strike jamb.

**2.5 Verification**

**2.5.1** Prior to installation, jobsite personnel shall ensure correct swing, size and labeling.

**2.6 Installation tolerances**

**2.6.1** While this document is mainly concerned with tolerances relating to the manufacturing process, openings will not function properly if the frame is not installed within recognized tolerances.

Figure 1 shows examples of the accuracy to be maintained while setting frames.

**3 Plumbing and bracing frames**

**3.1 Wood Spreaders** (see Figure 2)

The Contractor(s) responsible for installation shall have available a sufficient supply of wood

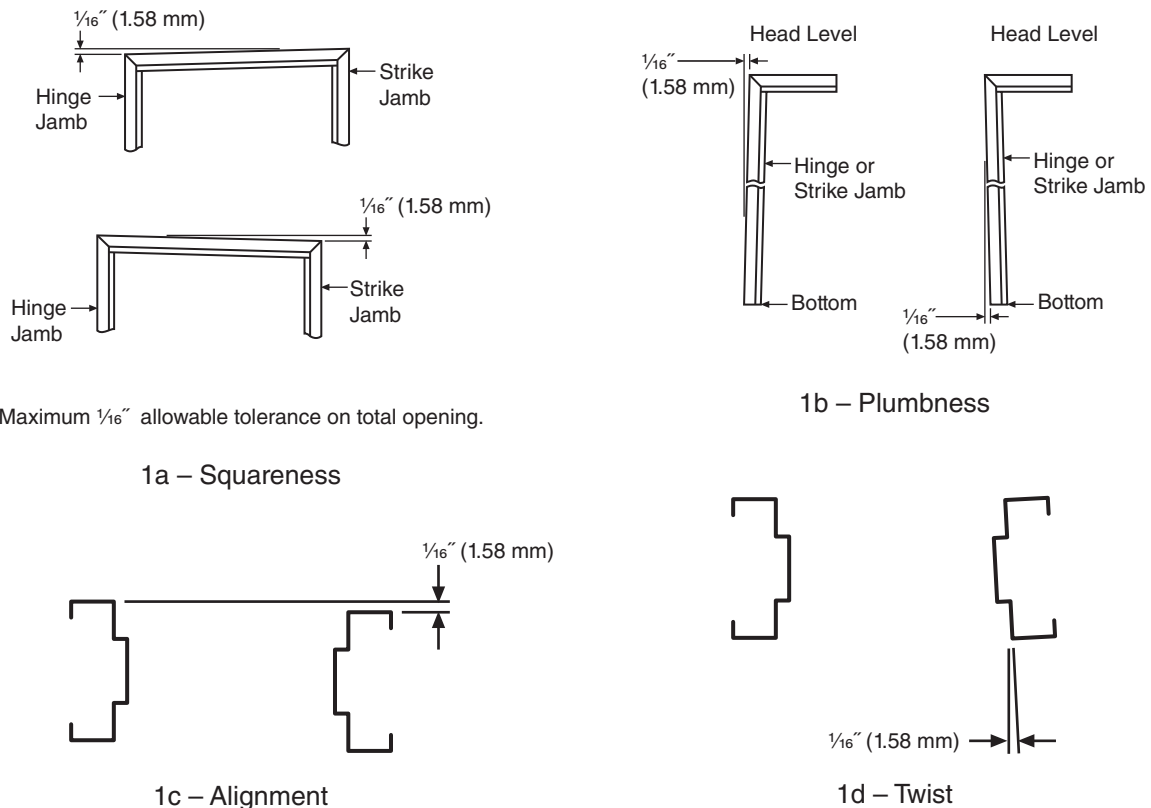

**Figure 1 – Examples of the accuracy to be maintained while setting frames**

spreaders for bracing frames. Spreader bars for shipping purposes shall not be used as installation spreaders.

**3.1.1** Wood spreaders shall be square and fabricated from lumber no less than 1" (25.4 mm) thick. Correct length is the door opening width between the jambs at the header (i.e., Single Door 3'-0" = 36" = 915 mm). Length tolerance is + $\frac{1}{16}$ ", -0" (+1.6 mm, -0). Cut clearance notches for frame stops. Spreader shall be nearly as wide as frame jamb depth for proper installation.

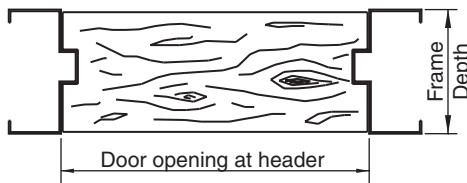
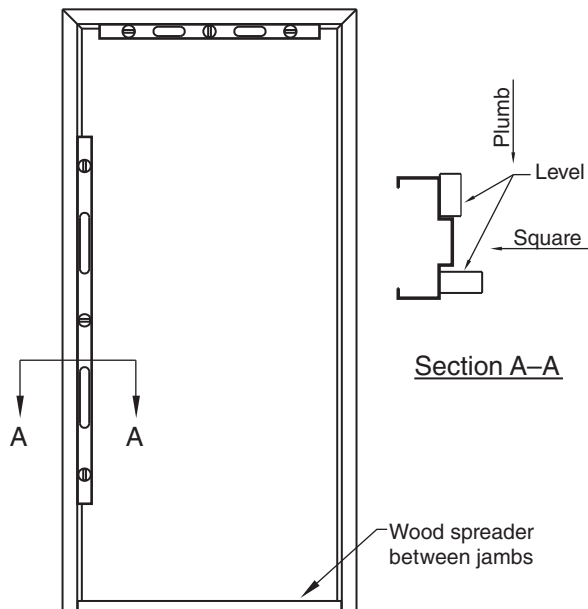

**Figure 2 – Spreader**

### 3.2 Equipment for plumbing the frame (see Figure 3)

**3.2.1** The contractor should be equipped with a carpenter level, square and wood spreaders.

**3.2.2** Where welded frames are provided with spreader bars, they shall be removed with a suitable saw or chisel and filed flush before setting frames.

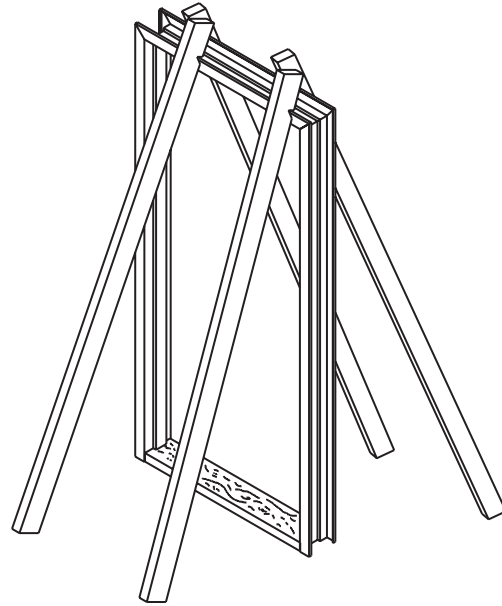

**Figure 3 – Plumbing the frame**

### 3.3 Bracing the frame (see Figure 4)

**3.3.1** Frame bracing shall be as shown or shore to a structure above.

**3.3.2** Bracing shall be perpendicular to the intended wall.



**Figure 4 – Bracing the frame**

### 3.4 Positioning the frame

**3.4.1** Set the frame in the desired location and level the header. Square jambs to header. Shim under jambs if necessary. With frame properly aligned, insert wood spreaders at bottom and mid-height and fasten jambs to floor through floor anchors.

**3.4.2** Plumb and square jambs. Install vertical brace to support header for openings over 4'-0" (1219 mm) wide.

## 4 Accessories

### 4.1 Install rubber silencers (see Figure 5)

**4.1.1** Cut the point from a #6d box or finishing nail. Insert nail in hole to elongate rubber silencers.

Moisten the end and insert rubber silencers in predrilled holes on frame stop, remove nail. The thickness of the silencer shall permit latching of door with  $\frac{1}{16}$ " to  $\frac{3}{32}$ " (1.6 to 2.4 mm) clearance between face of door and stop of frame.

**4.1.2** Install rubber silencers before frame erection to avoid grout filling rubber silencer

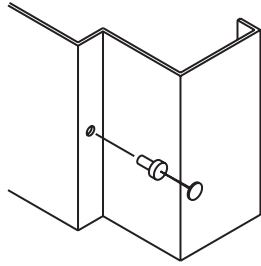

**Figure 5 – Rubber silencers**

holes. In some cases rubber silencers are factory installed.

**4.2 Extended base anchor** (see Figure 6)

**4.2.1** Extended base anchors are supplied upon request only. (If required for tool attachment.)

**5 New masonry construction** (see Figure 7)

**5.1** Assemble frame per manufacturer's instructions.

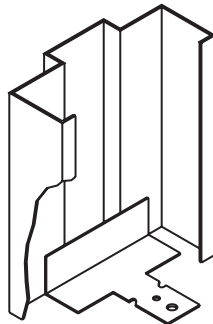

**Figure 6 – Extended base anchor**

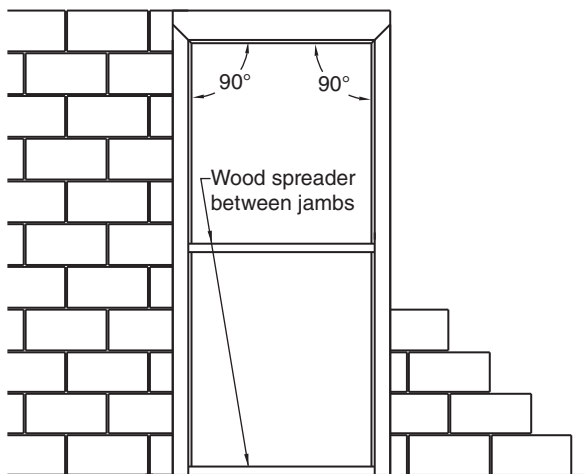

**Figure 7 – New masonry construction**

**5.2** Erect, brace, square and plumb frame.

**5.2.1** Fasten frame to floor through base anchors.

**5.3** Set second spreader at the mid-height of the door opening to maintain the door opening size.

**5.4** Install anchors (see Figure 8). Grout frame in the area of the anchors as block courses are laid up.

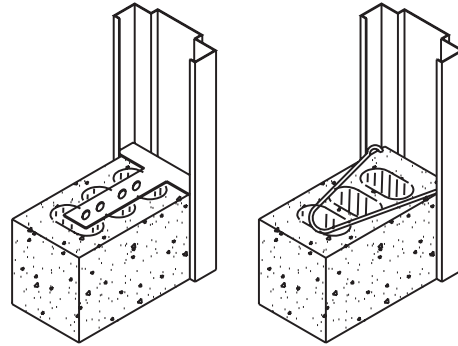

**Figure 8 – Masonry anchors**

**5.4.1** Frames may also be supplied with anchors welded in place.

**5.5** Continually check plumb and square as wall progresses.

**6 Existing masonry construction**

(see Figure 9, Figure 10, and SDI 127F)

**6.1** Rough openings for existing wall, structural steel framing, or retrofit installations utilizing a butted to wall application shall be no less than  $\frac{3}{16}$ " (4.8 mm) larger the frame on all three sides.

**6.1.1** The installer is responsible for any shimming or aligning required. Gaps are normally sealed as part of the installation or caulking/painting process.

**6.1.2** Refer to Architectural specifications for the appropriate sealant material to be used at fire or smoke control doors.

**6.2** Assemble frame per manufacturer's instructions.

**6.3** Install snap-in anchors (see Figure 11) and tap with a hammer to align with pierced holes in jambs.

**6.3.1** Frames may also be supplied with anchors welded in place.

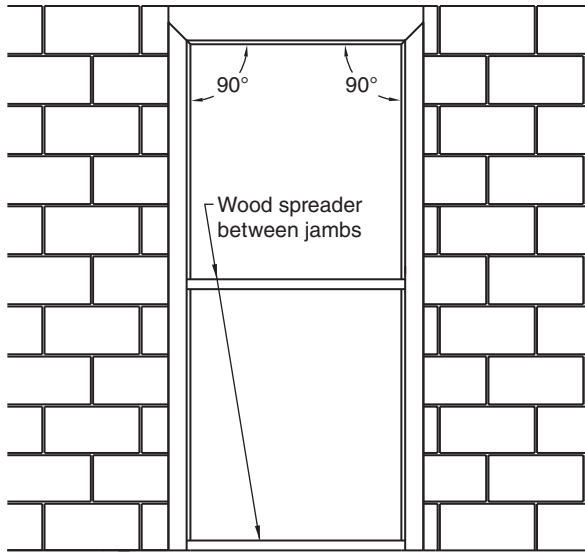

**Figure 9 – Existing masonry construction**

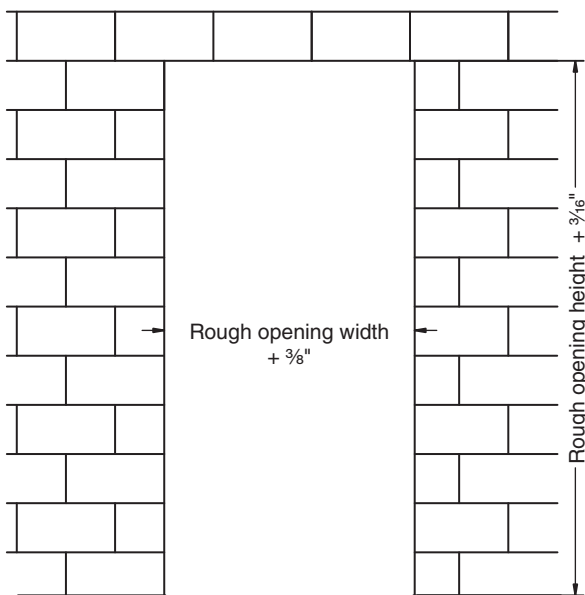

**Figure 10 – Rough Opening**

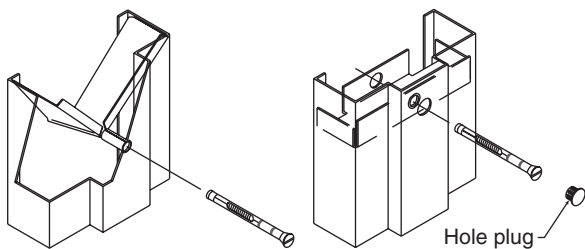

**Figure 11 – Existing masonry or concrete wall anchors**

**6.4** Slide frame into wall opening; install wood spreaders.

**6.5** Where possible, one jamb should be butted tightly to the wall.

**6.6** Use tapered shims between anchors and wall and spreaders to maintain squareness and alignment of frame, and to maintain door opening sizes.

**6.6.1** Drill appropriate size hole (per fastener manufacturer's instructions) for one-piece anchor bolts. Leave holes "rough" for added grip.

**6.6.2** Backer rod or caulking shall be used where gaps occur between frame and wall.

**6.7** Insert anchor bolts and tighten securely, checking for frame alignment periodically.

**6.8** Install plugs to cover bolt heads (if so equipped).

## **7 Steel stud wall construction, studs erected with frame** (see Figure 12)

**7.1** Assemble frame per manufacturer's instructions.

**7.2** Install snap-in anchors. Position anchors in frame through the throat and tap in with a hammer.

**7.2.1** Frames may also be supplied with anchors welded in place.

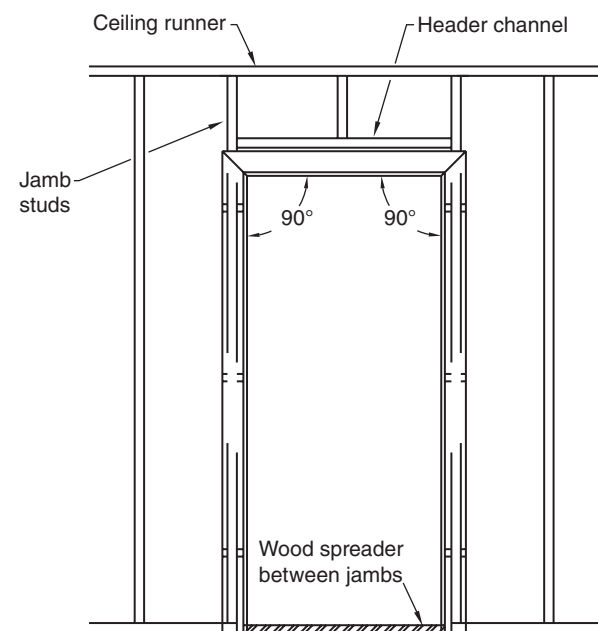

**Figure 12 – Steel stud wall construction**

**7.3** Erect, brace, square and plumb frame as shown.

**7.4** Install wood spreaders.

**7.5** Attach jambs to floor through floor anchor or floor extension.

**7.6** Install jamb studs to floor, header channels, and ceiling runners butted tightly against frame anchors and properly positioned in frame throat for wallboard.

**7.6.1** Nesting or overlapping stud joints or other wall construction practices that will increase the overall wall thickness beyond the intended finished thickness are to be avoided.

**7.7** Attach jamb studs to anchors with screws or weld.

**7.7.1** If using screws, drill from the back side of the stud, through both the stud and anchor, then attach with (2) screws per anchor location (see Figure 13). Screws shall be #6 x 3/8" minimum steel sheet metal or self tapping type.

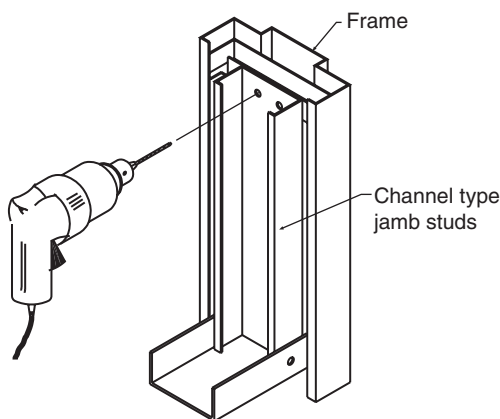

**Figure 13 – Channel type steel stud**

**7.7.2** When attaching header stud to jamb studs, be sure the stud is above frame header. This will assure ample room for attaching plaster lath or drywall and will not interfere with installation of hardware attached to frame header.

**7.7.3** At wrap-around installations in fire rated walls, drywall shall extend at least 1/2" (12.7 mm) into frame throat. See Section 12 for frame installations in butted or existing stud walls.

## 8 Double egress frames in steel stud wall construction

**8.1** Generally, the installation of double egress frames in steel stud walls follows the same procedure as Section 7.

**8.1.1** If frames are supplied knocked down, assemble per manufacturer's instructions.

**8.1.2** Install anchors (if not supplied welded to frame) per manufacturer's instructions.

**8.2** Erect, brace, square and plumb frame as shown (see Figure 14).

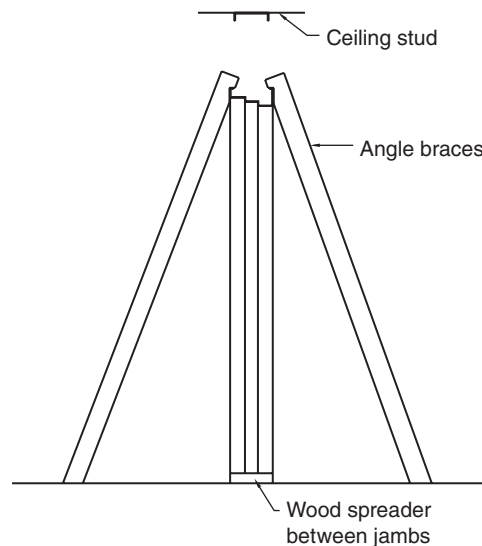

**Figure 14 – Erect frame**

**8.2.1** Stand frame up in desired location. Anchor one jamb to floor and set wood spreader on floor from anchored jamb to loose jamb.

**8.2.2** Install a vertical wood brace at center of frame.

**8.2.3** Position and anchor second jamb to floor. Plumb, level and square frame, then install wood spreaders at mid-height.

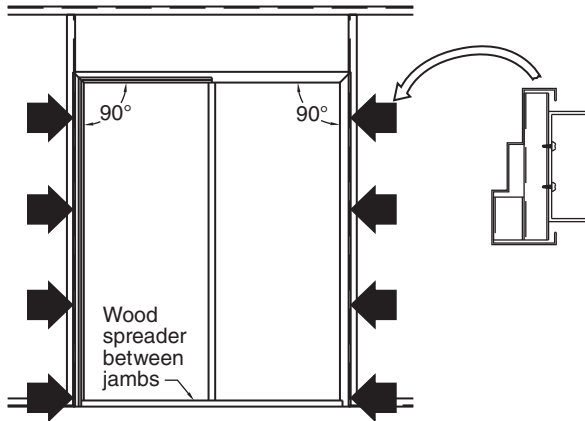

Figure 15 – Anchor jambs

### 8.3 Anchor jambs (see Figure 15)

**8.3.1** Install jamb studs to floor, header channels, and ceiling runners butted tightly against frame anchors and properly positioned in frame throat for wallboard.

**8.3.2** Nesting or overlapping stud joints or other wall construction practices that will increase the overall wall thickness beyond the intended finished thickness are to be avoided.

**8.4** Attach jamb studs to anchors with screws or weld.

**8.4.1** If using screws, drill from the back side of the stud, through both the stud and anchor, then attach with (2) screws per anchor location (see figure 15). Screws shall be #6 x  $\frac{3}{8}$ " minimum steel sheet metal or self tapping type.

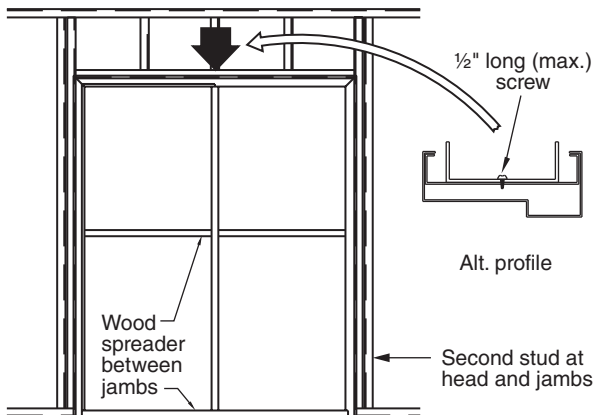

Figure 16 – Anchor header

### 8.5 Anchor header (see Figure 16)

Header anchor requirements will vary. The manufacturer's installation requirements should be followed.

**8.6** At wrap-around installations in fire rated walls, drywall shall extend at least  $\frac{1}{2}$ " (12.7 mm) into frame throat. See Section 12 for frame installations in butted or existing stud walls.

## 9 Wood stud construction (studs erected with frame)

**9.1** Assemble frame per manufacturer's instructions.

**9.2** Install snap-in anchors. Position anchors in frame through the throat and tap in with a hammer.

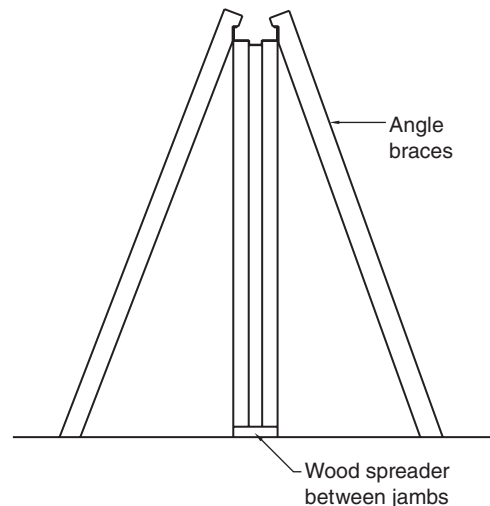

Figure 17 – Erect frame

**9.2.1** Frames may also be supplied with anchors welded in place.

**9.3** Square, brace and plumb frame as shown (see Figure 17).

**9.4** Install wood spreaders (see Figure 18).

**9.5** Attach jambs to floor through floor anchor or floor extension.

**9.6** Install jamb studs (jack stud and king stud) butted tightly against anchors and properly positioned in frame throat for wallboard (see Figure 18).

**9.6.1** Attach header stud(s) or header assembly between jamb studs making sure they are

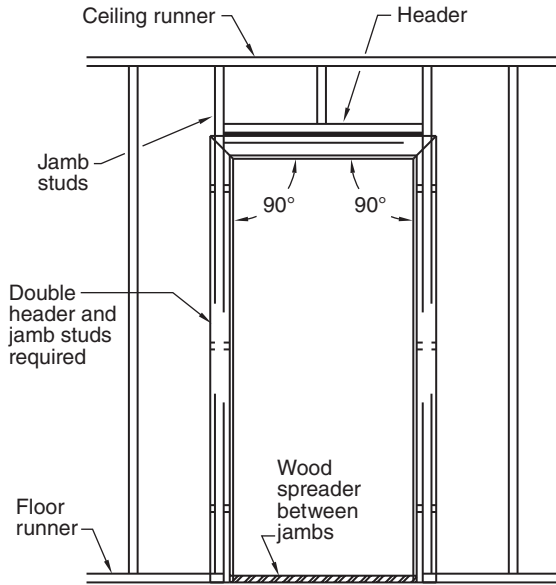

**Figure 18 – Wood stud wall construction**

above the frame head. This will assure ample room for attaching plaster lath or drywall and will not interfere with installation of hardware attached to frame head (see Figure 18).

**9.7** Bend anchor straps around stud leaving sufficient clearance between frame return and stud for inserting finished wall material (see Figure 19 and Figure 20).

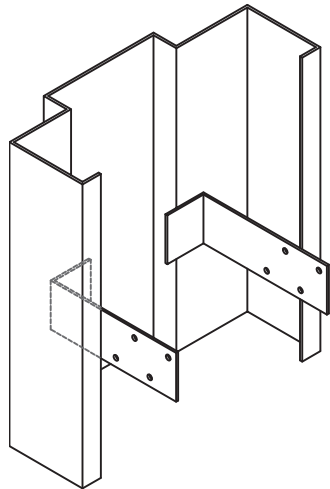

**Figure 19 – Weld in strap anchors wood/steel studs**

**9.7.1** If there is insufficient room for wall finish, notch jamb studs no more than 1/16" (1.6 mm) deep for anchor straps.

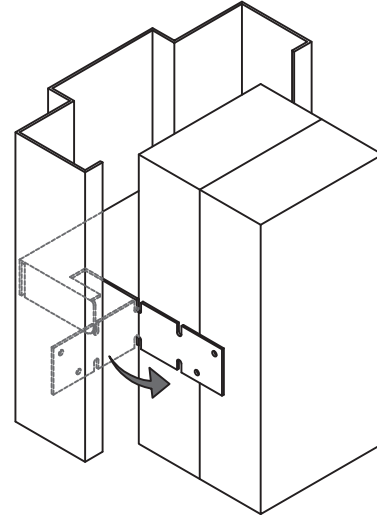

**Figure 20 – Snap or weld in anchors wood/steel studs**

**9.8** Square and nail top anchor to stud on ONE JAMB ONLY. Check plumb and square and continue to nail balance of anchors to stud. Repeat for opposite jamb. For steel studs install screws from back of stud into Z anchor (see Figure 21).

**9.8.1** At wrap-around installations in fire rated walls, drywall shall extend at least 1/2" (12.7 mm) into frame throat. See Section 12 for frame installations in butted or existing stud walls.

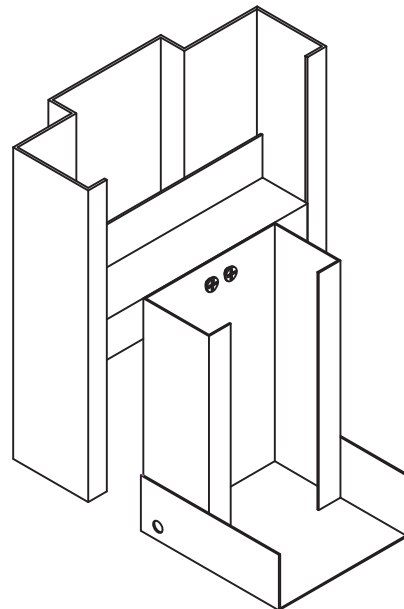

**Figure 21 – Z Type weld in anchors steel studs**



## 10 Wood/steel stud construction (studs erected before frame)

10.1 Build rough opening (see Figure 22) according to dimensions and clearances in manufacturer's installation instructions.

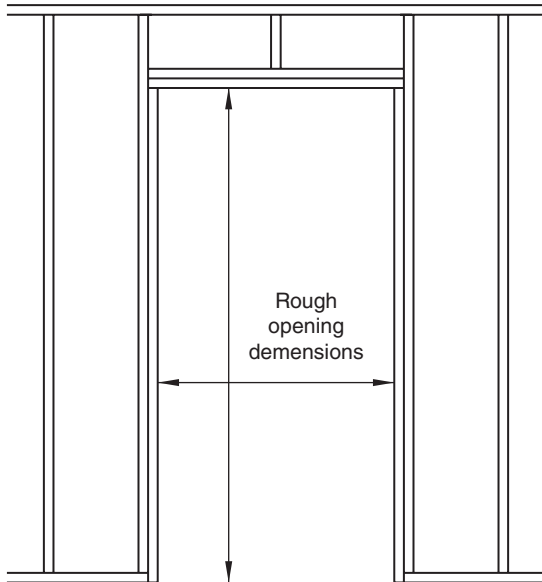

Figure 22 – Rough opening shown in wood stud.

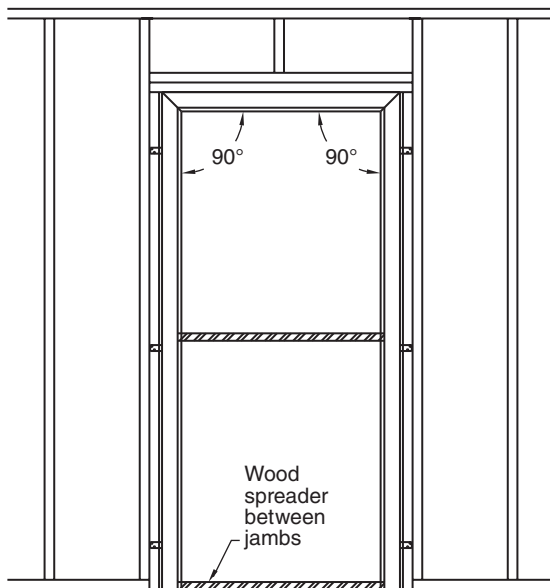

Figure 23 – Wood stud wall construction

10.1.1 Assure that rough openings are no less than those required in SDI 127F.

10.1.2 It is recommended that double studs be used at jambs and headers.

10.2 Assemble frame per manufacturer's instructions.

10.3 Install snap-in anchors. Position anchors in frame through the throat and tap in with a hammer.

10.3.1 Frames may also be supplied with anchors welded in place.

10.3.2 If base anchors cannot be used add one anchor per jamb at bottom.

10.3.3 Install fire rated frames with the anchor quantity and spacing as per the individual manufacturer's listings and instructions.

10.4 Slide frame into wall opening.

10.4.1 Install wood spreaders at bottom and mid-height. Square and level frame. Shim jambs if necessary (see Figure 23).

10.5 Bend anchor straps around stud leaving sufficient clearance between frame return and stud for inserting finished wall material (see Figure 24 and Figure 25).

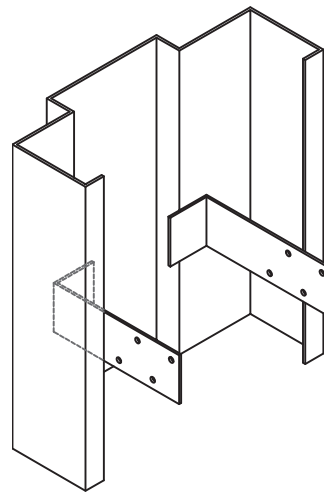
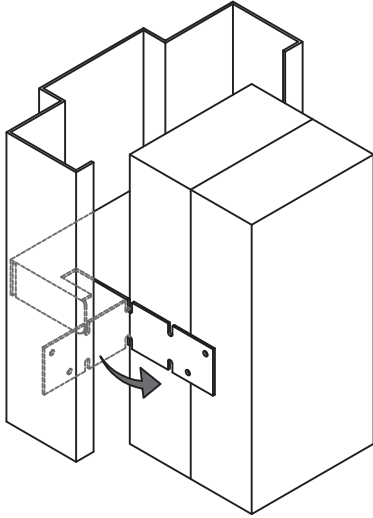
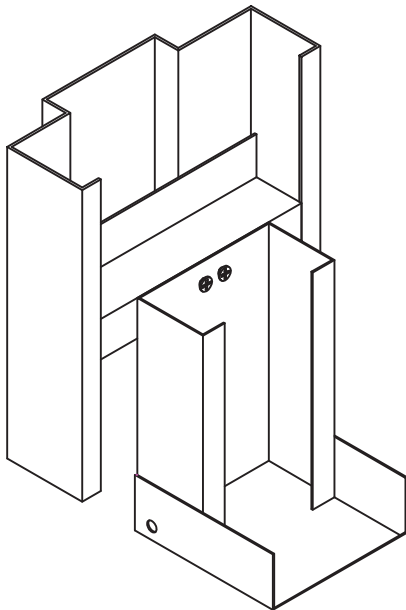

Figure 24 – Weld in strap anchors wood/steel studs



**Figure 25 – Snap or weld in anchors wood/ steel studs**

**10.6** Square and nail top anchor to stud on ONE JAMB ONLY. Check plumb and square and continue to nail balance of anchors to stud. Repeat for opposite jamb. For steel studs install screws from back of stud into Z anchor (see Figure 26)



**Figure 26 – Z Type weld in anchors steel studs**

**10.6.1** NOTE: At wrap-around installations in fire rated walls, drywall shall extend at least ½" (12.7 mm) into frame throat. See Section 12 for frame installations in butted or existing stud walls.

## 11 Slip-on drywall

**11.1** Prepare rough opening (see Figure 27) per frame manufacturer's recommendations.

**11.1.1** Nesting or overlapping stud joints or other wall construction practices that will increase the overall wall thickness beyond the intended finished thickness are to be avoided.

**11.2** Install base anchors if not factory welded to jambs or if frame faces are not prepared for base anchor screws.

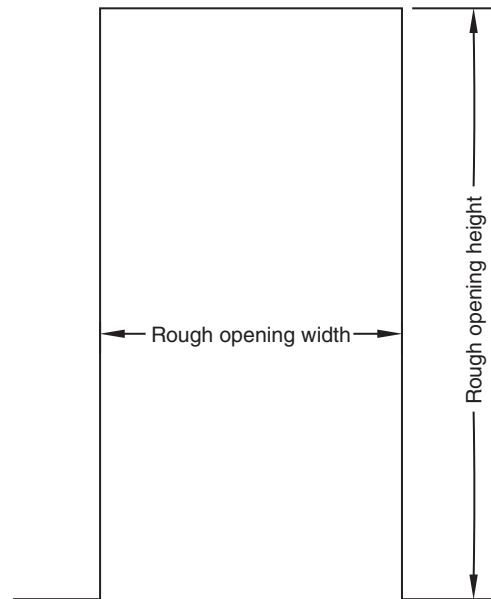

**Figure 27 – Rough opening**

**11.3** Install jambs and header onto wall per manufacturer's instructions, taking care to align corner gussets (if so equipped). See Figure 28.

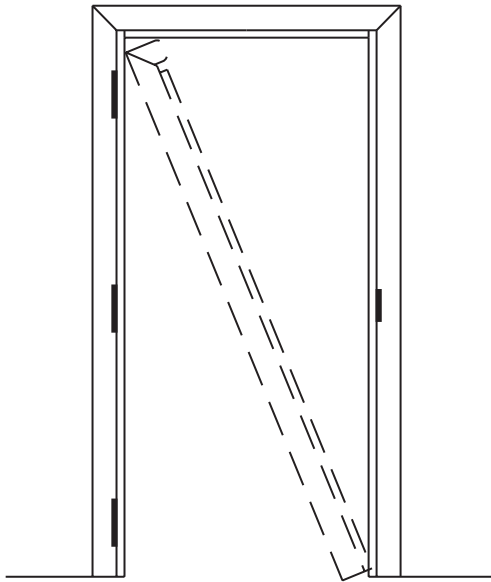
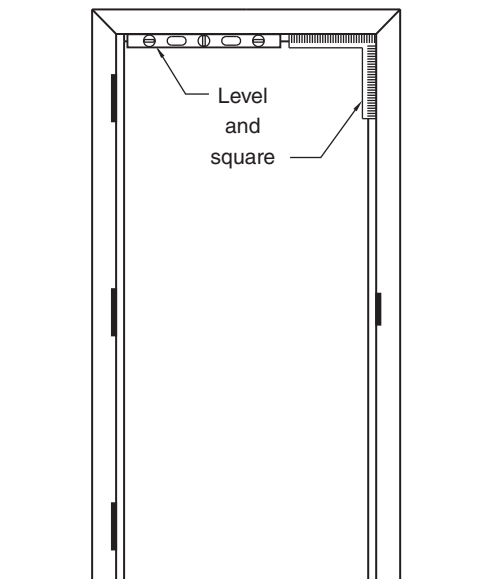

**Figure 28 – Align corner gussets**

**11.4** Level and square frame (see Figure 29)

**11.4.1** Install wood spreaders.

**11.5** Turn adjusting screws hand tight (DO NOT USE SCREW GUN) until compression anchor contacts jamb studs. See Figure 30.



**Figure 29 – Level and square frame**

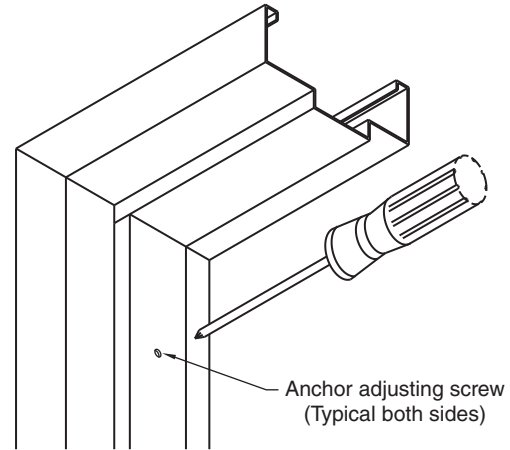

**Figure 30 – Anchor adjusting screw**

**11.6** Re-check level and square. Adjust using anchor screws as needed.

**11.7** Fasten base anchors to wall stud (see Figure 31) or fasten to wall studs through prepared holes in face of jambs at bottom.

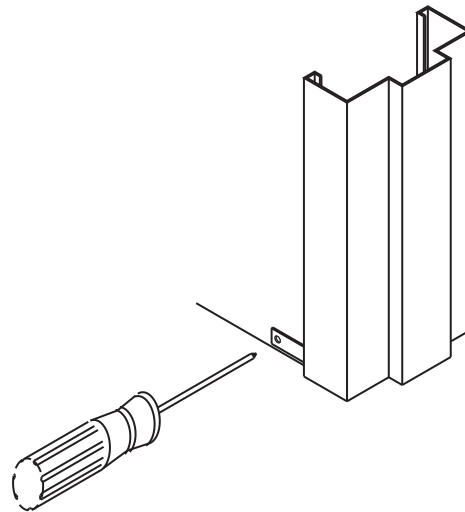

**Figure 31 – Fasten base anchors to wall stud**

## **12 Butted or Existing Steel or Wood Stud Wall Construction**

**12.1** Historically, frames installed in fire rated stud walls required frames to wrap around the wall and drywall must extend at least ½" (12.7 mm) into frame throat. Fire testing has

confirmed that fire door frames will perform satisfactorily to the acceptance criteria of UL 10C under positive pressure when butted to new or existing stud and drywall construction (see Figure 32 and Figure 33).

**12.1.1** This installation has been incorporated into NFPA 80 as Figure A.6.3.1.3(a) and A.6.3.1.3(b).

**12.1.2** Applicable Building Codes and individual manufacturers' product listings shall be consulted when these butted frames are used in fire rated walls.

**12.1.3** This installation process DOES NOT apply to Slip-on Drywall frames in Section 11.

**12.1.4** Listed fill, void or cavity material shall be used at the junction of frame faces and returns with the drywall surface. The bead of fill, void or cavity material shall be no wider than 1/2" (12.7 mm).

**12.2** Assemble knock down frames per manufacturer's instructions.

**12.3** Anchors are typically welded to frames and will either be a sleeve aligned with a countersunk hole or a plate between returns with an access hole and plug.

**12.4** Assure that rough opening or opening between walls is plumb, square, and properly sized to fit overall frame dimensions and expansion capability of intumescent caulk or sealant. (See SDI 127F for further information).

**12.5** Using a "stud finder" or similar tool, assure that studs will align with frame mounting screws.

**12.6** Slide frame into wall opening; install wood spreaders at the floor and mid-height of opening.

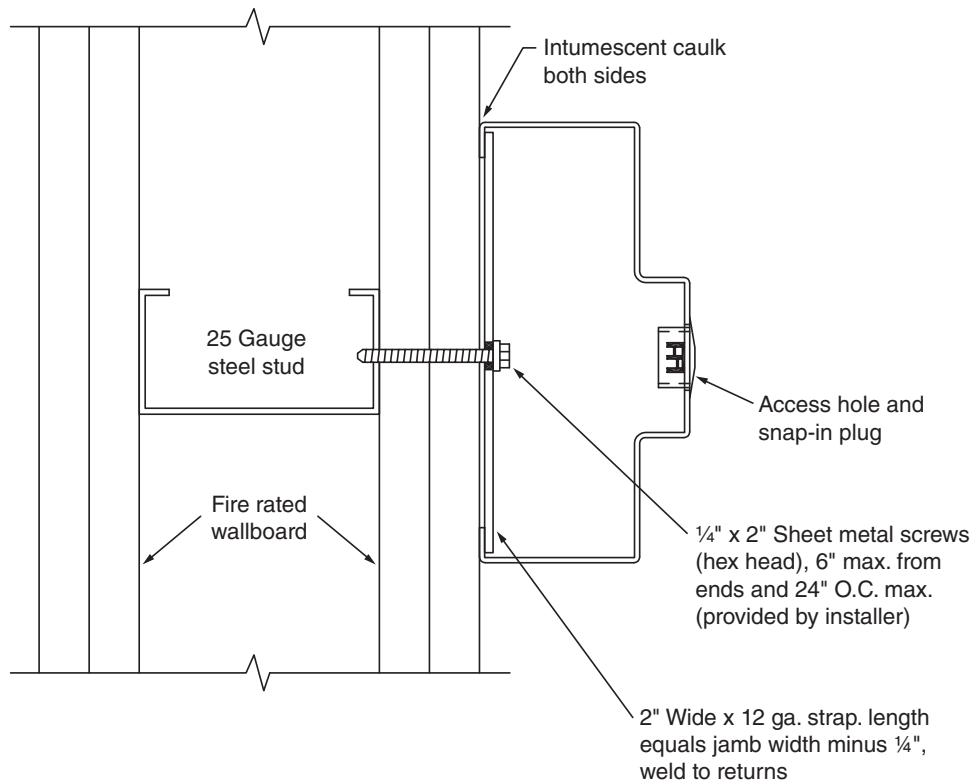

**Figure 32 – Hole plug mount**

**12.7** Use tapered shims between anchors and wall and spreaders to maintain squareness and alignment of frame and to maintain door opening. Make sure that shims will not interrupt the sealant.

**12.8** Insert  $\frac{1}{4}$ " (6.4 mm) sheet metal screws of suitable length to engage studs through countersink or access hole in frame (see Figure 32 and Figure 33) and tighten securely. Check

for frame alignment periodically. (Frame profiles shown are for general details only. Anchors and profiles may vary).

**12.9** Insert plugs to cover access holes if so equipped.

**12.10** Install Listed intumescent caulk or sealant around perimeter of frame, making sure to cover any gaps caused by irregularities in walls.

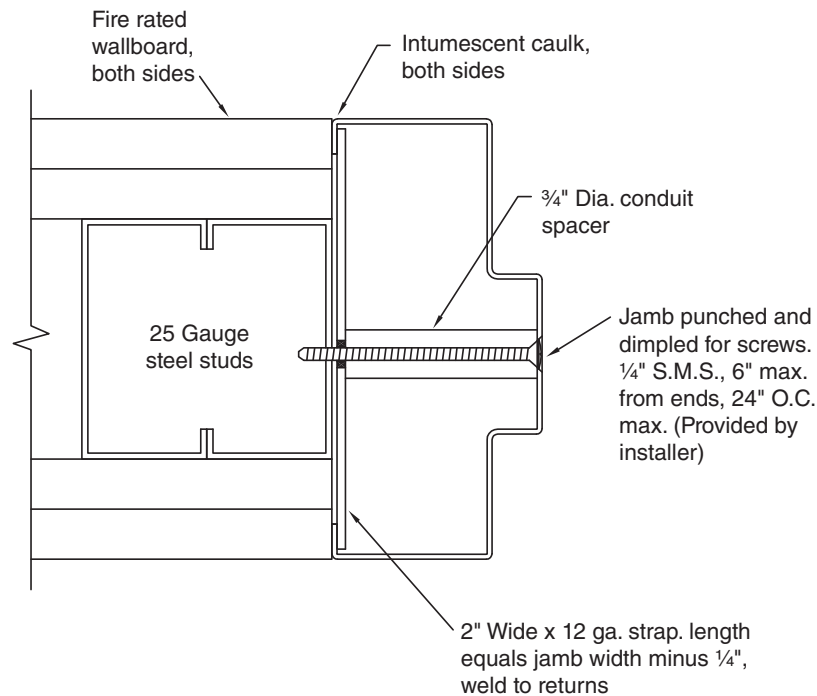

**Figure 33 – Countersink mount**

## Annex A (informative)

### Manufacturing Tolerances for Standard Steel Doors and Frames

#### A1 Introduction

It is the intent of this publication to inform users of standard steel doors and frames with definitive information regarding manufacturing tolerances. It is also intended to inform the installation contractor(s) of the tolerances to be considered to assure proper operation of the complete opening. It is intended for in-plant inspections. It may be used for on-site inspections where there is no evidence of damage to material or improper installation.

The information contained herein pertains to doors and frames manufactured in accordance with ANSI A250.8, *Recommended Specifications for Standard Steel Doors and Frames*. It is not intended to have reference to special or unusual door and frame conditions.

#### A2 Reference Documents:

ANSI/SDI A250.8-2003 (R2008) *SDI 100 Recommended Specifications for Standard Steel Doors & Frames*

ANSI/SDI A250.6-2003 (R2009) *Recommended Practice for Hardware Reinforcings on Standard Steel Doors and Frames*

ANSI/SDI A250.7-1997 (R2002) *Nomenclature for Standard Steel Doors & Steel Frames*

ANSI/SDI A250.3-2007 *Test Procedure & Acceptance Criteria for Factory Applied Finish Coatings for Steel Doors & Frames*

ANSI/SDI A250.10-1998 (R2004) *Test Procedure & Acceptance Criteria for Prime Painted Steel Surfaces for Steel Doors & Frames*

ANSI/BHMA A156.115-2006 *Hardware Preparation in Steel Doors and Steel Frames*

ANSI/BHMA A156.115-W-2006 *Hardware Preparation in Wood Doors with Wood or Steel Frames*

ASTM A568-09 *Standard Specification for Steel, Sheet, Carbon, Structural, and High-Strength, Low-Alloy, Hot-Rolled and Cold-Rolled, General Requirements for*

ASTM A653-10 *Standard Specification for Steel Sheet, Zinc-Coated (Galvanized) or Zinc-Iron Alloy-Coated (Galvannealed) by the Hot-Dip Process*

ASTM A924-10 *Standard Specification for General Requirements for Steel Sheet, Metallic-Coated by the Hot-Dip Process*

NFPA 80-2010 *Standard for Fire Doors and Other Opening Protectives*, 2007 Edition (National Fire Protection Association, 1 Batterymarch Park, Quincy, MA 02269; www.nfpa.org)

SDI 122-07 *Installation and Troubleshooting Guide for Standard Steel Doors and Frames*

#### A3 Materials and Finishes

##### A3.1 Steel Thickness:

Manufacturers no longer order sheet and coil to a specific gage, but rather to a minimum decimal thickness. This thickness is the lowest of the range for a specific gage. The steel supplier is therefore permitted to exceed, but not be less than the specified decimal thickness. These minimum values meet the stringent requirements of both Underwriters Laboratories Inc. and ITS/Warnock Hersey. Examples of minimum allowable steel thickness:

Gage (MSG)	Minimum
20	0.032"
18	0.042"
16	0.053"
14	0.067"
12	0.093"
10	0.123"
7	0.167"

Gage (MSG) are for reference purposes only.

### A3.2 Steel Coatings

Thickness of metallic coatings (generally zinc) are defined by ASTM A924, *Standard Specification for General Requirements for Steel Sheet, Metallic-Coated by the Hot-Dip Process* and A653, *Standard Specification for Steel Sheet, Zinc-Coated (Galvanized) or Zinc-Iron Alloy-Coated (Galvannealed) by the Hot-Dip Process*. The two most commonly used are designations A40 and A60. Minimum requirements for these designations are:

A40= 0.40 oz/ft<sup>2</sup> total both sides.

A60= 0.60 oz/ft<sup>2</sup> total both sides.

For reference, 1 oz/ft<sup>2</sup> = 1.7 mils thickness.

### A3.3 Factory Applied Coatings:

Since factory applied coatings (primer, finish paint, etc.) are subject to performance standards rather than thickness, the dry film thickness is irrelevant. Such coatings must comply with performance criteria of:

ANSI/SDI A250.3 – *Test Procedure and Acceptance Criteria for Factory Applied Finished Painted Steel Surfaces for Steel Doors and Frames*

OR

ANSI/SDI A250.10 – *Test Procedure and Acceptance Criteria for Prime Painted Steel Surfaces for Steel Doors and Frames*.

## A4 Frame Tolerances

### A4.1 Frame Cross Section Profile

Permissible tolerances in frame profile surfaces are as shown in Figure A.

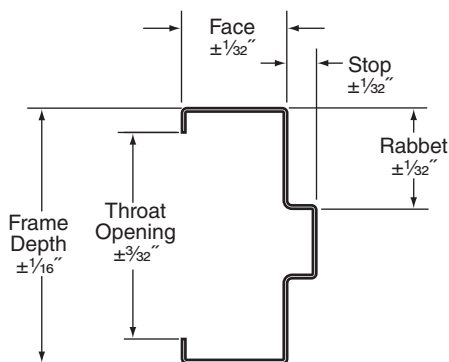

Figure A – Profile Tolerances

### A4.2 Frame Opening & Vertical Locations

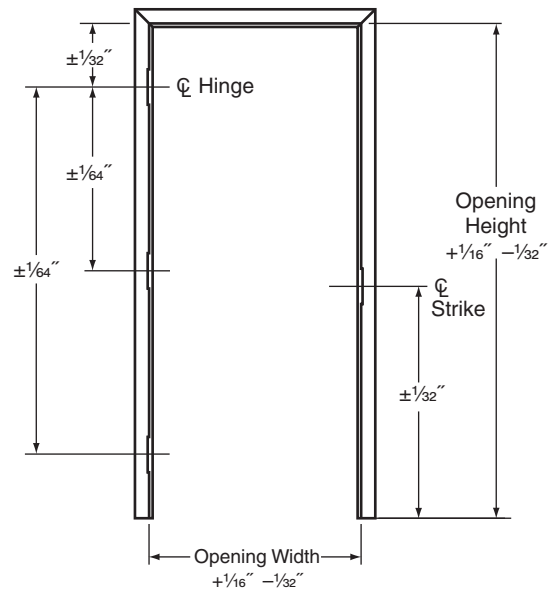

Figure B – Opening Tolerances

### A4.3 Bow or Twist of Jambs or Header

Realizing that frames are somewhat “pliable”, and require bracing and alignment during installation, allowable deformation (bow, twist, etc.) of jambs or header of frame **prior to installation** shall not result in a reduction of opening sizes more than  $\frac{1}{16}$ ” beyond those shown in Figure B when measured at any point.

### A4.4 Horizontal Alignment of Door Within Rabbet

Hinge and strike backsets shall allow the horizontal centerline of the door to be in line with the horizontal centerline of the frame rabbet  $\pm \frac{1}{32}$ ” **prior to installation**. Figure C is an example based on a  $1 \frac{3}{4}$ ” door in a  $1 \frac{15}{16}$ ” rabbet.

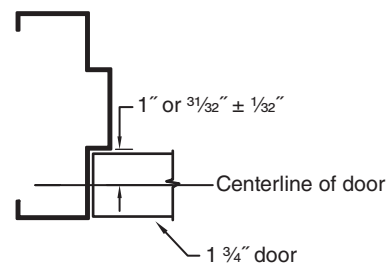

Figure C – Horizontal Alignment

#### 4.5 Frames With Lights or Panels

Opening sizes (width or height) for side or transom lights or panels and for borrowed light frames shall be subject to a tolerance of  $\pm 1/16''$  for each individual light or panel. These tolerances shall be non-accumulative so that the overall frame opening sizes are not increased by more than  $1/8''$  (see Figure D).

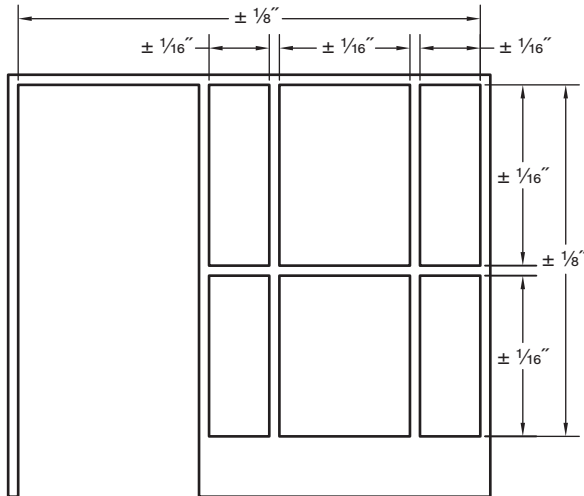

Figure D – Frames with Lights or Panels

### A5 Door Tolerances

#### A5.1 Door Size, Thickness, and Vertical Locations (see Figure E)

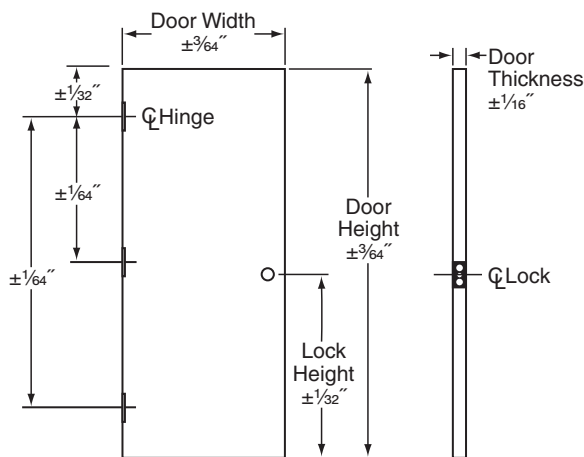

Figure E – Doors

#### A5.2 Door Squareness

When measured diagonally (see Figure F) from corner to corner along the same face, the measurements shall be within  $1/16''$  of each other.

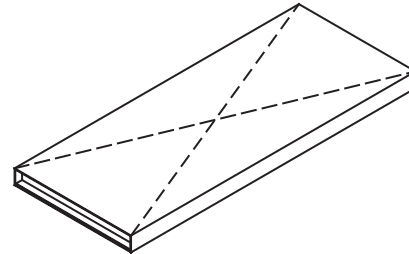

Figure F – Squareness

#### A5.3 Door Perimeter Flatness

When a suitable straightedge is laid against the door face at or within  $1/4''$  of the top, bottom, hinge edge, and lock edge on both faces any deviation between the face and the straightedge shall not allow a 0.0625'' rod or block to pass (see Figure G). **Note:** The straightedge shall be allowed to “rest” naturally on the door surface, not pulled down at one end to meet the door.

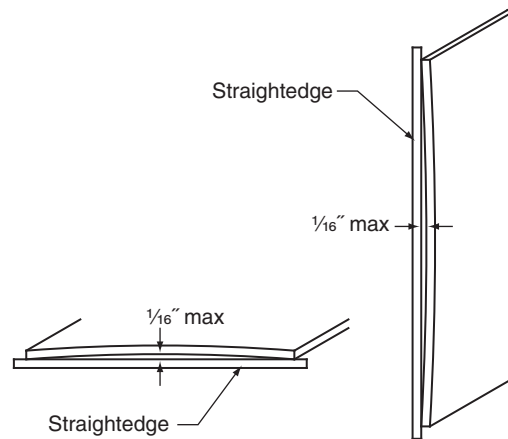

Figure G – Flatness

#### A5.4 Door Face Bow or Crown

When a suitable straightedge is laid diagonally against the door face at least  $1/2''$  from corners any deviation between the face and the straightedge shall not allow a 0.125'' rod or block to pass (see Figure H). Note: The straightedge



shall be allowed to “rest” naturally on the door surface, not pulled down at one end to meet the door.

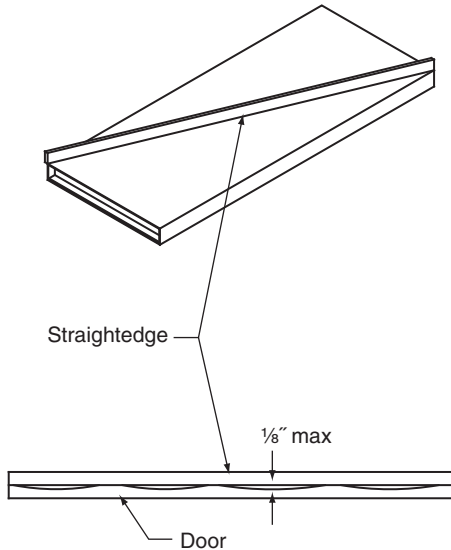

**Figure H – Door face bow or crown**

#### A5.5 Door Twist

The door is laid onto a suitable, flat fixture or surface that is free of any warp, bow, or twist. Support blocks of identical heights shall be

inserted between the fixture and the door face at all four corners of the door. Any deviation between the face and the support blocks shall not allow a 0.0625” rod or block to pass (see Figure I). Note: The door shall be allowed to “rest” naturally on the support blocks, not pulled down at any corner to meet the blocks.

#### A5.6 Doors With Lights or Panels

Opening sizes (width or height) for lights or panels cut into doors shall be subject to a tolerance of  $\pm 1/16$ ” for each individual light or panel.

### A6 Hardware Preparations

#### A6.1 Vertical Locations

Tolerances for vertical locations are as noted in Paragraphs A4.2 and A5.1.

#### A6.2 Horizontal Alignment

Tolerances for horizontal alignment of door and rabbet are as noted in Paragraphs 4.4.

#### A6.3 Mortise Depth

The depth of hardware items mortised into edges of doors (such as hinges, strikes, lock fronts, flushbolts) shall be as defined on manufacturer’s templates and/or ANSI A156.115 documents subject to an additional tolerance of  $\pm 1/64$ ”

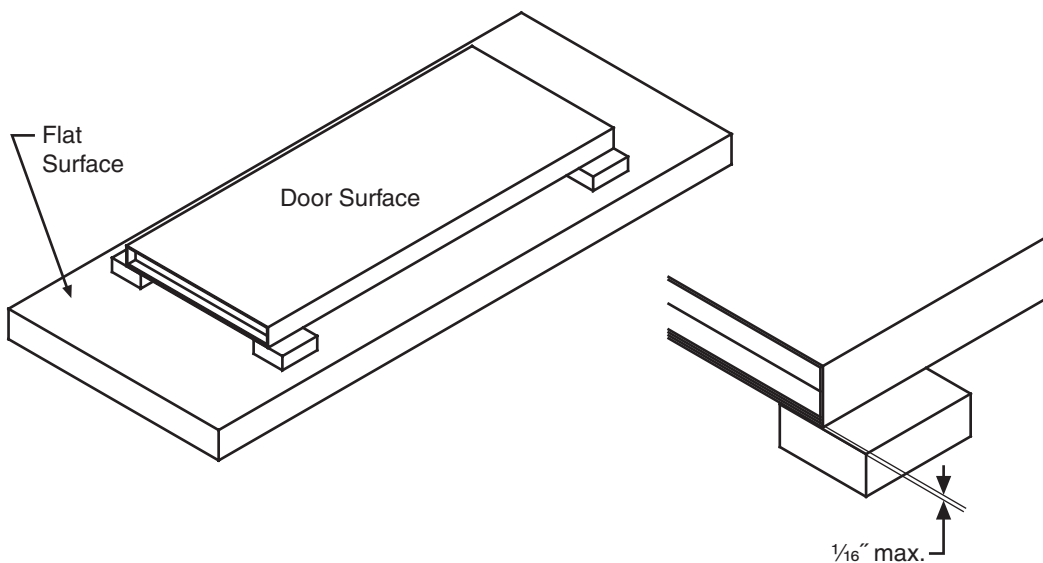

**Figure I – Door Twist**

### A6.3.1 Cutout Depth at Frame or Door Faces

In order to allow for field adjustment, usually accomplished by shimming, hardware cutouts (such as hinges) that extend from door edges around to faces or from frame rabbet around to faces are allowed to exceed mortise depth by  $\frac{1}{16}$ ". See Paragraph A7 for examples of common hinge shimming procedures.

### A6.3.2 Depth For Recessed or Concealed Hardware

The depth for hardware items recessed into top or bottom of doors or edges of doors (such as pocket pivots, floor closers, top pivots, concealed closers or holders, etc) shall be as defined on manufacturer's templates subject to an additional tolerance of  $+\frac{1}{16}$ ",  $-0$ ". Notches in door faces shall have similar tolerances.

## A7 Frame Installation And Door Adjustments

### A7.1 Adjusting Pivot Point by Shimming

Providing extra depth along door or frame faces allows for hinge knuckles to be offset, thus changing the pivot point of the opening.

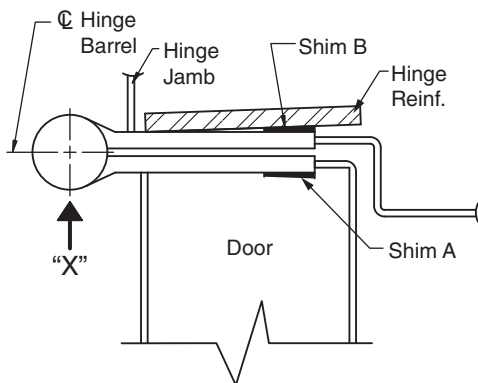

- Using shim A only, door will be relocated in the direction of arrow "X".
- Using shim B only, will move both door and centerline of hinge barrel in direction of Arrow "X".
- Using both shims A and B will relocate the door in direction of Arrow "X" by a greater amount than by using shim "B" alone.

Figure J – Hinge Bind

Shims are usually thin strips of  $\frac{1}{4}$ " wide material approximately equal to the hinge height.

**A7.1.1** Figure J shows how to relocate the pivot point toward the jamb.

**A7.1.2** Figure K shows how to relocate the pivot point away from the jamb.

### A7.2 Frame Installation Tolerances

While this document is mainly concerned with tolerances relating to the manufacturing process, openings will not function properly if the frame is not installed within recognized tolerances.

Figures L, M, N, and O show examples of the accuracy to be maintained while setting frames.

### A7.3 Troubleshooting

Further information regarding corrective actions for of door & frame openings may be found in SDI-122.

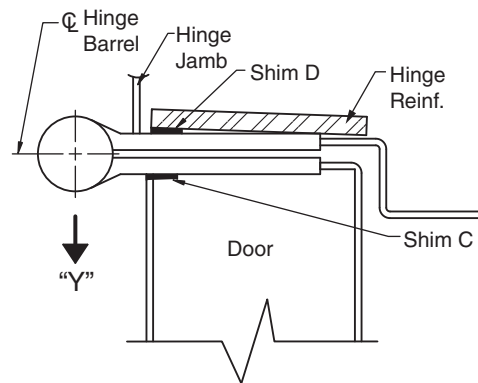

- Using shim C only, door will be relocated in direction of Arrow "Y".
- Using D only, both door and centerline of hinge barrel will move in the direction of Arrow "Y".
- Using both shims C and D will relocate the door in direction of Arrow "Y" by a greater amount than by using either C or D alone. The centerline of hinge barrel will be relocated the same as by using shim D alone.

Figure K – Hinge Bind

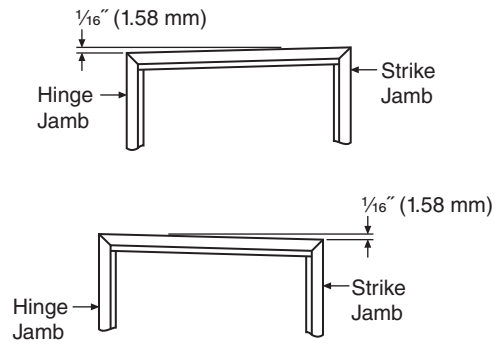

Maximum  $\frac{1}{16}$ " allowable tolerance on total opening.

**Figure L – Squareness**

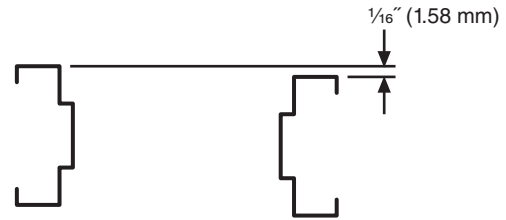

**Figure N – Alignment**

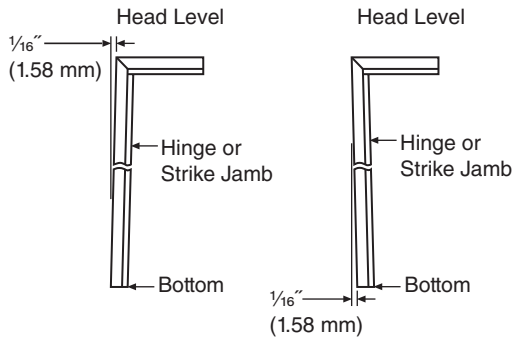

**Figure M – Plumbness**

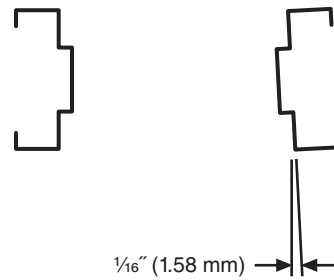

**Figure O – Twist**

**Annex B**  
(informative)

**Installation Exceptions**

The installation instructions contained in ANSI A250.11 are intended to apply to most typical frame installations. There are, however, certain types of frames for which additional wood spreaders are recommended during the frame installation to ultimately assure the proper door operation.

Three-sided frames with face dimensions of 1-½" or less of any opening size, frames for doors that weigh over 9 lbs. per square foot and/or frames of heights greater than 8'-0" are more prone to variations in installed tolerances. Under most conditions, frames such as these require more support during the installation process.

For installations such as these, the SDI recommends the use of wood spreaders at the bottom of frames **AND** at 36" intervals between the top and bottom as indicated in the illustration below.

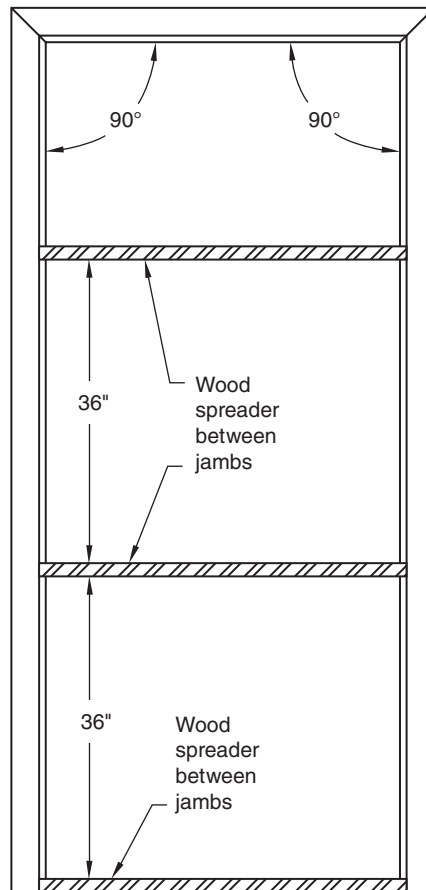

**This page left intentionally blank.**

**This page left intentionally blank.**

**This page left intentionally blank.**

---

## AVAILABLE PUBLICATIONS

---

### Specifications

- ANSI/SDI A250.6** Recommended Practice for Hardware Reinforcings on Standard Steel Doors and Frames
- ANSI/SDI A250.8** SDI 100 Specifications for Standard Steel Doors & Frames
- SDI-108** Recommended Selection & Usage Guide for Standard Steel Doors
- SDI-118** Basic Fire Door, Fire Door Frame, Transom/Sidelight Frame, and Window Frame Requirements
- SDI-128** Guidelines for Acoustical Performance of Standard Steel Doors & Frames
- SDI-129** Hinge & Strike Spacing

### Test Procedures

- ANSI/SDI A250.3** Test Procedure & Acceptance Criteria for Factory Applied Finish Coatings for Steel Doors & Frames
- ANSI/SDI A250.4** Test Procedure & Acceptance Criteria for Physical Endurance for Steel Doors, Frames and Frame Anchors
- ANSI/SDI A250.10** Test Procedure & Acceptance Criteria for Prime Painted Steel Surfaces for Steel Doors & Frames
- ANSI/SDI A250.13** Testing and Rating of Severe Windstorm Resistant Components for Swinging Door Assemblies for Protection of Building Envelopes (Not applicable for FEMA 320/361 or ICC-500 Shelters)
- SDI-113** Standard Practice for Determining the Steady State Thermal Transmittance of Steel Door & Frame Assemblies
- SDI-131** Accelerated Physical Endurance Test Procedure for Steel Doors, Frames and Frame Anchors

### Construction Details

- ANSI/SDI A250.11** Recommended Erection Instructions for Steel Frames
- SDI-110** Standard Steel Doors & Frames for Modular Masonry Construction
- SDI-111** Recommended Details for Standard Details Steel Doors, Frames, Accessories and Related Components
- SDI-122** Installation Troubleshooting Guide for Standard Steel Doors & Frames

### Miscellaneous Documents

- SDI-112** Zinc-Coated (Galvanized/Galvannealed) Standard Steel Doors & Frames
- SDI-117** Manufacturing Tolerances for Standard Steel Doors & Frames
- SDI-124** Maintenance of Standard Steel Doors & Frames
- SDI-127** Industry Alert Series (A-L)
- SDI-130** Electrified Hinge Preparations
- SDI-134** Nomenclature for Standard Steel Doors & Steel Frames

**AUDIO-VISUAL PROGRAMS ALSO AVAILABLE**

---

## MEMBERS OF THE STEEL DOOR INSTITUTE

---

### **CECO DOOR**

9159 Telecom Drive  
Milan, TN 38358  
(731) 686-8345  
[www.cecodoor.com](http://www.cecodoor.com)

### **CURRIES**

P.O. Box 1648  
Mason City, IA 50402-1648  
(641) 423-1334  
[www.curries.com](http://www.curries.com)

### **DEANSTEEL MANUFACTURING CO.**

931 S. Flores Street  
San Antonio, TX 78204-1406  
(210) 226-8271  
[www.deansteel.com](http://www.deansteel.com)

### **DOOR COMPONENTS INC.**

7980 Redwood Avenue  
Fontana, CA 92336-1638  
(909) 770-5700  
[www.doorcomponents.com](http://www.doorcomponents.com)

### **HOLLOW METAL XPRESS**

602 S. 65th Avenue  
Phoenix, AZ 85043  
623-936-7000  
[www.HMXpress.com](http://www.HMXpress.com)

### **MESKER DOOR, INC.**

3440 Stanwood Boulevard  
Huntsville, AL 35811-9021  
(256) 851-6670  
[www.meskerdoor.com](http://www.meskerdoor.com)

### **MPI**

319 North Hills Road  
Corbin, KY 40701  
(606) 523-0173  
[www.metalproductsinc.com](http://www.metalproductsinc.com)

### **PIONEER INDUSTRIES, INC.**

171 South Newman Street  
Hackensack, NJ 07601  
(201) 933-1900  
[www.pioneerindustries.com](http://www.pioneerindustries.com)

### **REPUBLIC DOORS & FRAMES**

155 Republic Drive  
McKenzie, TN 38201-0580  
(731) 352-3383  
[www.republicdoor.com](http://www.republicdoor.com)

### **SECURITY METAL PRODUCTS**

5700 Hannum Avenue, Suite 250  
Culver City, CA 90230  
(310) 641-6690  
[www.secmet.com](http://www.secmet.com)

### **STEELCRAFT**

9017 Blue Ash Road  
Cincinnati, OH 45242  
(513) 745-6400  
[www.steelcraft.com](http://www.steelcraft.com)



Standards As Tough As Steel.™

---

# STEEL DOOR INSTITUTE

---

30200 DETROIT ROAD • CLEVELAND, OHIO 44145

440.899.0010 • FAX 440.892.1404

[www.steeldoor.org](http://www.steeldoor.org)